

SECTION III
Principles of Operation

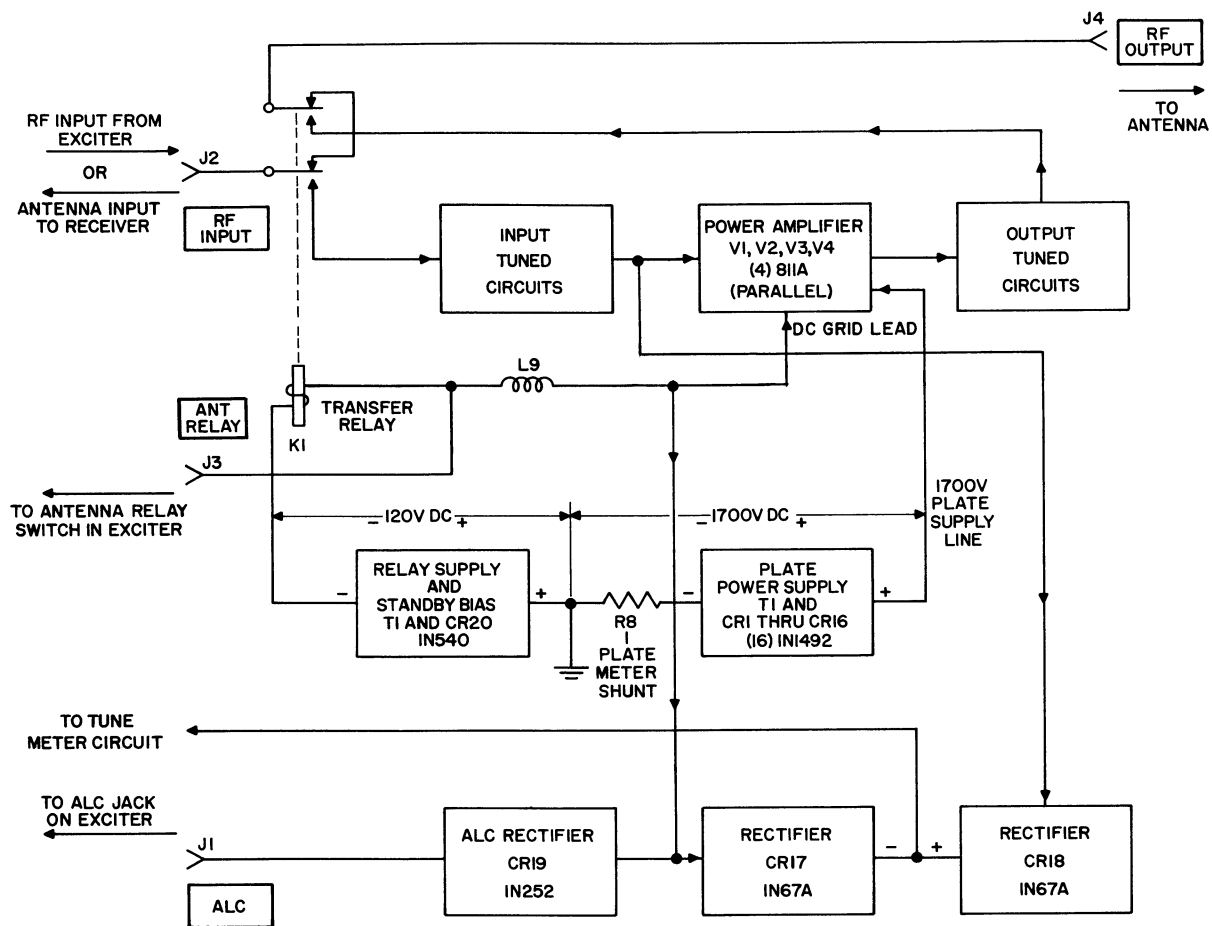

Figure 3-1. 30L-1 Block Diagram

SECTION III PRINCIPLES OF OPERATION

3.1 GENERAL.

The 30L-1 is a portable r-f linear power amplifier, including plate power and bias supplies. It is capable of 1000 watts PEP input power in SSB or 1000 watts d-c input in CW service with any exciter (such as the KWM-1, KWM-2/2A, or 32S-1) capable of 70 watts PEP output. It covers the amateur bands between 3.5 and 29.7 mc. In addition, the amplifier may be operated outside the amateur bands over certain ranges of frequency. These ranges are specified in table 4-1. The power amplifier stage uses four 811A triodes connected in parallel with cathode drive.

3.2 INPUT CIRCUITS.

Refer to figures 3-1 and 7-2. Broadband pi-network circuits couple the exciting signal into the cathode circuits of the power amplifier tubes. The tuned input circuits provide increased efficiency, reduced distortion, and a better impedance match for the exciter than normally would be obtained with an untuned input. Tuning adjustments are not required except for operation outside the amateur bands.

3.3 OUTPUT CIRCUITS.

The plate circuit of the power amplifier is tuned by a pi network consisting of C32, L9, L10, and C33. Capacitor C32 resonates the tank circuit at the frequency in use. It is adjusted by the TUNING control on the front panel. The four-gang capacitor, C33, is adjusted by the LOADING control to match the pi-network circuit to the impedance presented by the antenna and feed system in use. Output from the plate tank circuit is connected through the contacts of antenna changeover relay, K1, to the antenna when the control circuits are energized.

3.4 POWER SUPPLY CIRCUITS.

Two d-c power supplies and one a-c filament supply are included in the 30L-1. The amplifier may be connected to a 115-volt single-phase or to a 230-volt, three-wire, single-phase source. Where practical, the 230-volt, three-wire connection is recommended. Power transformer T1 has two primary windings. These windings are connected in parallel for 115-volt operation, and in series for 230-volt operation. The 6.3-volt secondary winding provides filament power for the 811A tubes through r-f choke L8. It also powers the pilot lamp in the meter. Another secondary winding applies voltage through surge resistor R9 to semiconductor rectifier CR20. This is a half-wave circuit connected to furnish blocking bias to the amplifier tubes under receive conditions and operating bias when transmitting. It also furnishes power for changeover relay K1. Voltage from the third secondary winding is

applied to two semiconductor rectifier strings connected in a full-wave voltage doubler configuration. These strings consist of CR1-CR8, C44-C51 in one string, and CR9-CR16, C52-C59 in the other. The parallel capacitors equalize the reverse voltages impressed across the diode junctions and protect against damage by transients. The output of this supply provides approximately 1600 volts d-c under load for the amplifier tube plates.

3.5 SAFETY INTERLOCK CIRCUITS.

The r-f and power supply compartment covers operate safety interlock switches for operator protection. Switch S5 is located in the power supply compartment. Switches S6 and S7 are located in the r-f compartment. Cover removal closes these switches and shorts the high voltage to ground. This arrangement protects the operator from accidentally coming in contact with high-voltage d-c which is present in either compartment.

WARNING

DO NOT BLOCK INTERLOCK SWITCHES. Contact with voltages in this equipment can be fatal. Be sure to disconnect the a-c power plug before removing any of the covers.

3.6 POWER CONTROL CIRCUITS.

Refer to figure 3-2. The front-panel ON-OFF switch breaks one side of the a-c line in the OFF position. When operated to the ON position, a-c power is applied to the power transformer primaries and the tube-cooling fan B1. Overload protection is provided by eight-ampere fuses F1 and F2. These are used for both 115-volt a-c and 230-volt a-c operation.

3.7 ALC CIRCUITS.

Automatic load control (alc) is a compressor circuit operating at radio frequencies. In the 30L-1, the grid-to-plate capacitances of the amplifier tubes in conjunction with capacitors C22, C23, C24, and C25 form capacitive voltage dividers. Under modulation, an r-f voltage is developed across these dividers and L3. It is coupled to the alc rectifier CR19 through capacitor C72. The r-f voltage is rectified and filtered to produce a negative d-c control voltage which is proportional to the modulation level. (The load resistor for CR19 must be provided by the exciter alc circuits.) This voltage is applied to the control grid of a low-level r-f amplifier tube or tubes in the exciter. The time constants of these circuits have a fast

SECTION III
Principles of Operation

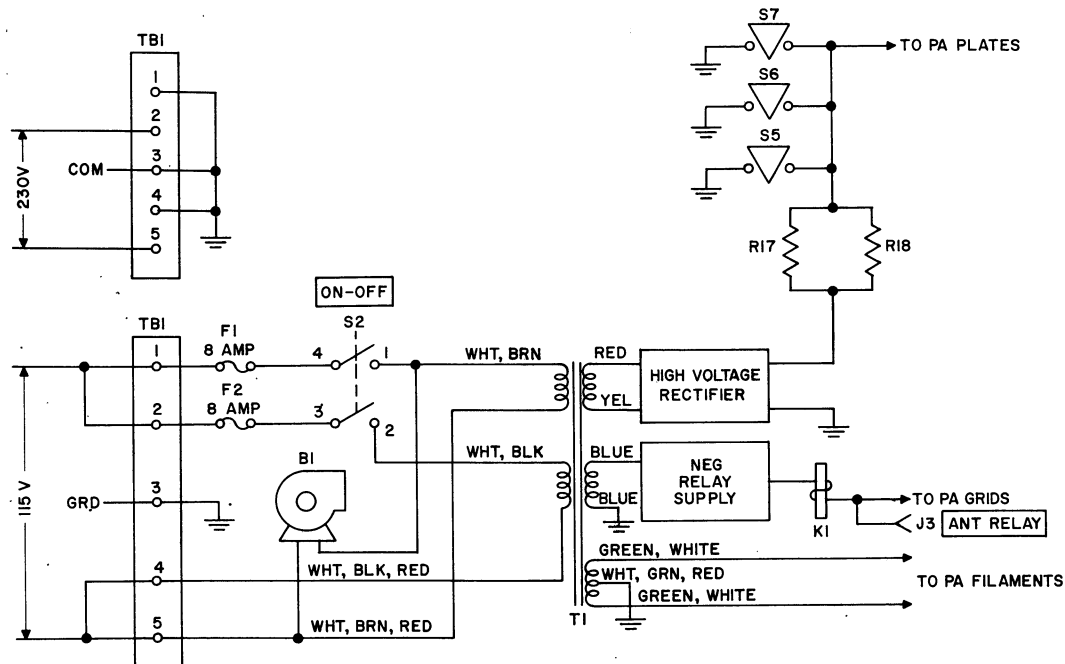

Figure 3-2. Control and Interlock Circuits

attack, slow-release characteristic. The alc threshold is controlled by the amount of reverse bias on CR19. This voltage is developed across R7 in the plate supply bleeder network, and varied by potentiometer R16. It is adjusted at the factory for optimum operation in conjunction with the internal alc circuits of exciters such as the KWM-1, KWM-2/2A, or 32S-1. Normally it will not need readjustment.

This system allows a high average level of modulation and optimum power output from the amplifier, within the rated limits of distortion.

3.8 METERING CIRCUITS.

One section of the METER switch, S3, selects the output voltage from a tuning and loading bridge circuit.

This circuit consists of the power amplifier tubes, CR17, CR18, and the associated load resistors and filter networks. The bridge is balanced when the plate circuit TUNING and LOADING controls are adjusted to present the proper load impedance to the power amplifier plates. The meter then will read zero.

The second section of the meter switch connects the meter to the plate supply through a four-megohm multiplier resistor to indicate the d-c voltage output. It is read on the D.C. KILOVOLT scale.

The third section of the meter switch connects the meter, through R10, across shunt, R8. This indicates power amplifier plate current. It is read on the D.C. AMPS scale.