

Home-Brew the Blockbuster

In a heroic effort, WB2WIK has created the ultimate 6-meter amplifier. Its single 4-1000A delivers over 2 kW with only 20 Watts in. The power supply alone weighs 120 pounds. When this monster talks, people listen!

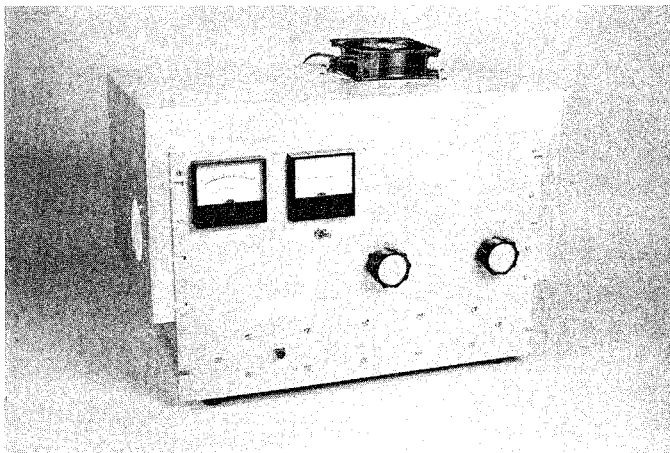

Photo A. The six-meter Blockbuster.

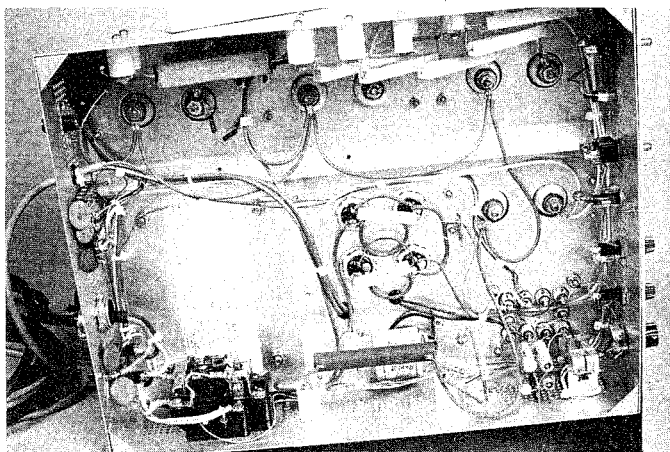

Photo B. Power supply, bottom view.

Although I enjoy rag-chewing, DX-chasing, contesting, satellite work, and just about every conceivable aspect of amateur radio, the activity I enjoy most of all is home-brewing, especially home-brewing with a purpose. This article describes a reasonably ambitious effort which was precipitated by a very distinct purpose: I wanted to become more competitive in VHF contests, especially on the 50-MHz band where a few more dB could add multipliers via meteor scatter when band conditions are less than perfect. I call the result my "Blockbuster."

I had been using a rather modest kilowatt amplifier on six meters, a single 4CX350A at about 600 Watts PEP output, and I wanted to QRO right to the legal limit of 1.5 kW PEP out. While this is only about a 4-dB increase in signal, I reasoned that it would be the most important 4 dB of all, especially in contests where scatter-mode communication is very important for added

multipliers. I toyed with the idea of using such exotic tubes as 8877s, 4CX1500s, or possibly the new Eimac 3CX800, but dismissed these as too expensive or, in the case of the 8877, too hard to drive. I really wanted a legal-limit amp which could be driven with today's solid-state multimode rigs (perhaps 20 Watts PEP output) and which used an inexpensive, obtainable tube. Hmm...what about the old, reliable 4-1000A?

For the uninitiated, the 4-1000A is a workhorse tetrode that has been around forever and is usable to 110 MHz despite its overwhelming stature (about nine inches tall, five inches in diameter). The plate dissipation rating is 1000 Watts and the tube can be operated in grid-driven class AB₂ service at well over the legal power limit with only 20 Watts drive. Not only that, the real charm of the 4-1000A is its availability at reasonable cost. This is a very popular broadcast-service tube and "pulls," which still will deliv-

er 1500 Watts PEP output, are offered at flea markets for about \$50 to \$100, a far cry from the price tag on an 8877.

My desire to operate the project amplifier in grid-driven rather than grounded-grid service was the result of careful investigation of the parametric trade-offs. A grounded-grid 4-1000A, certainly an easier amp to build, requires over 100 Watts drive and *might* deliver 1500 Watts PEP output, while a grid-driven circuit, obviously more complex, only requires 20 Watts drive and should deliver 2000 Watts PEP output easily!

Not one to flaunt all this power, especially in a national magazine probably read by FCC staffers, I'll just say that I reasoned a 2-kW+ amplifier should really sound good and should last a long time when run at the reduced legal limit of 1500 Watts.

I built the power supply first. This is a matter of personal preference, but I strongly recommend that anyone attempting this project follow my lead and tackle the power supply right off. The power supply is going to be very heavy and a mighty pain in the neck to assemble largely because of its muscle-building bulk, and if you don't finish this half of the job at the start, you might never get to it.

My power supply is actually three power supplies built on a single chassis measuring 17" x 13" x 4" and then bolted to a 12" x 19" rack panel. The aluminum chassis has perforated side walls to enhance air circulation beneath, and it wouldn't have been strong enough to support all the transformers and capacitors if I hadn't first given it additional support by means of some 3/4" aluminum angle stock riveted under the whole length and half the width—see Photo B. (My thanks to WA2VUN and

W2HWC who did much of the aluminum punching, riveting, and welding on this project.)

After the power supply was completed, I added more 3/4" aluminum angle stock between the rear of the chassis and the back side of the panel to add support and also to give me a place to grab when attempting to lift this turkey! My supply weighs 120 pounds, but possibly yours can be somewhat lighter if you choose less bulky components.

Because I know the 4-1000A is both voltage- and current-hungry, I designed the plate supply to deliver 4000 volts at one Ampere. This may sound like overkill, and maybe it is, but I wanted this thing to last through a lot of contests. I bought a Hypersil transformer from the Peter W. Dahl Company (El Paso, Texas) for something over \$200. Its ratings

are 6000 volts center-tapped at 800 mA CCS, and it weighs about fifty pounds. Careful shopping at flea markets might possibly turn up something similarly rated for less money.

I run the plate supply as a full-wave center-tap using two 7500-volt, 2-Amp rectifier stacks and 16 uF of filtering (4 each, 4 uF at 4 kV). The high-voltage capacitors are large but weren't expensive—obtained from Fair Radio Sales (Lima, Ohio) via mail order. The plate-supply bleeder is a bank of five 30k-Ohm, 30-Watt wire-wound ceramic resistors mounted on ceramic standoffs. The plate transformer, needless to say, is supplied by a "stiff" 230-volt-ac line and the primary is dual-fused (each side of the 230-volt line) with 20-Amp slow-blow fuses and switched with a 25-Amp DPST relay.

The screen supply delivers 500 V dc at 100 mA and

is so stiff it requires no additional electronic regulation. I used a multi-winding transformer obtained from Fair Radio Sales. The 700-volt center-tapped secondary drives a full-wave (center-tap) rectifier circuit followed by a 70-uF filter and a 20k-Ohm bleeder and delivers almost exactly 500 volts of low-ripple dc. The screen transformer center-tap is also relay-switched to ensure that the plate supply is on *before* the screen supply. Catastrophic results are likely otherwise.

The power supply also contains the grid-bias supply, which delivers two output voltages: -165 V dc for standby and -60 V dc, adjustable plus or minus 20%, for operating. I derive the bias from a full-wave bridge rectifier driven by a 6.3-V filament transformer which is wired back-to-back across a 6.3-V-ac winding of the screen transformer. The

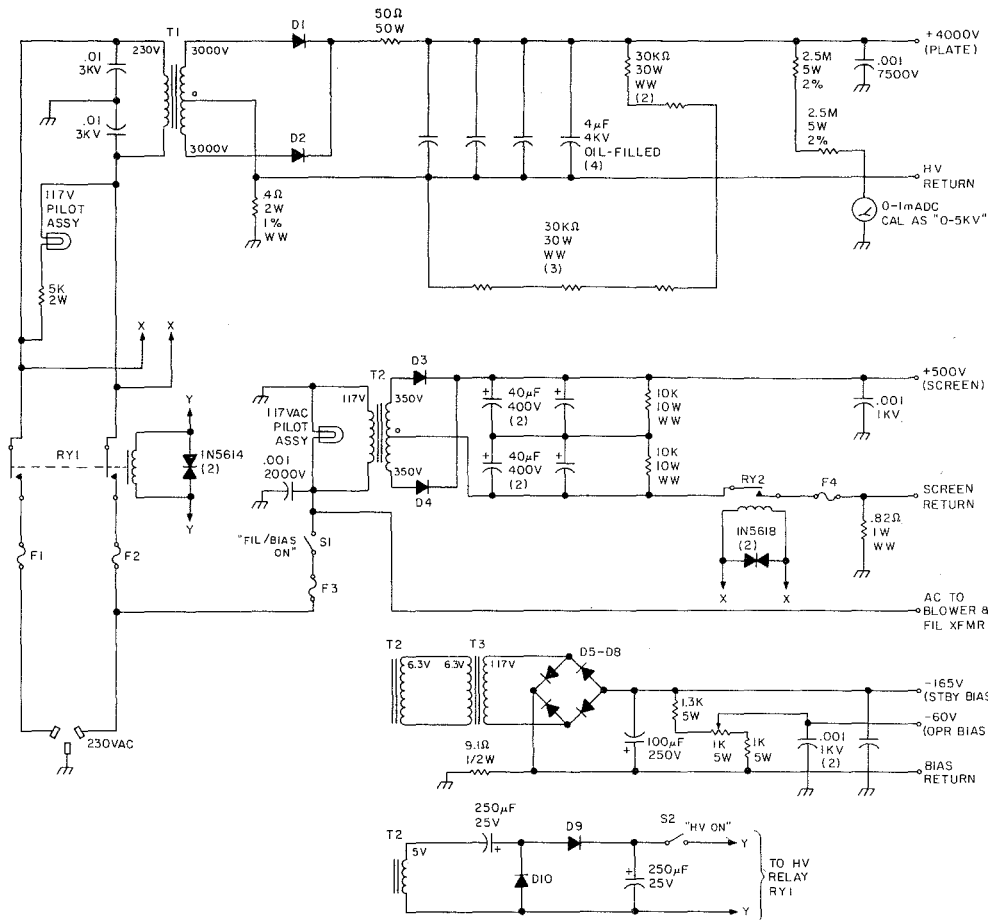

Fig. 1. Power supply.

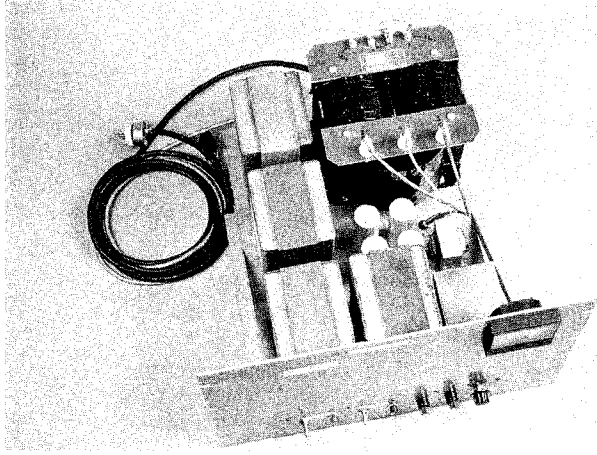

Photo C. Power supply, top view.

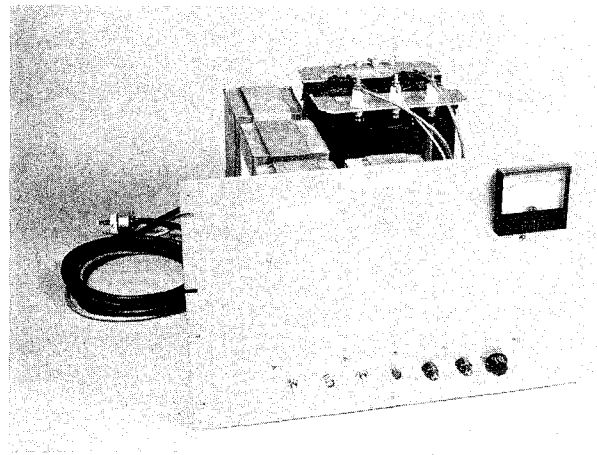

Photo D. Power supply, front view.

117-volt-ac drive to the bridge yields -165-V-dc output, filtered by a 100- μ F, 250-V capacitor. The bleed-resistor-string values were chosen to make a voltage divider which sets the adjustable operating bias in the range required for a 4-1000A in class AB₂.

The high-voltage (plate) transformer is switched (as mentioned) by a large relay whose coil is driven by a little 12-volt-dc power supply built into the system for just this purpose: I made this 12-V-dc supply by voltage-doubling a 5-V-ac winding which happened to be an-

other secondary of the screen transformer (I told you this was a multi-function unit!). The ripple and regulation of this supply is unimportant since its only load is a relay coil. I use the plate-transformer primary to drive the screen relay, thus ensuring that the plate sup-

ply is on before the screen supply. This is a good safety measure because tetrodes get very excited about having screen voltage before plate voltage (it destroys the screen).

My supply has a built-in plate voltmeter (0-1-mA-dc meter driven by a series-multiplier string of five one-megohm resistors) which reads 0-5000 volts dc. This is a useful scale since the key-up voltage is 4500 V (key-down is about 4100 V). The supply also contains shunts for plate-current, screen-current, and grid-current meters which are mounted on the panel of the rf deck. These are all indicated on the schematic diagram for the power supply (Fig. 1).

I also have a "keyed" 117-V-ac output line coming from the power supply to the rf deck to run the deck-contained blower, filament transformer, and pilot lamp. The power supply contains two pilot lamps (ac on and HV on) plus several fuse assemblies. All ac inputs, ac outputs, and dc outputs are bypassed with suitable ceramic capacitors as indicated on the schematic. The 4-kV plate-supply output is bypassed with 7.5-kV "door-knob" capacitors since not many other types will withstand this kind of voltage continuously.

At this power level, even the ac line cord must be se-

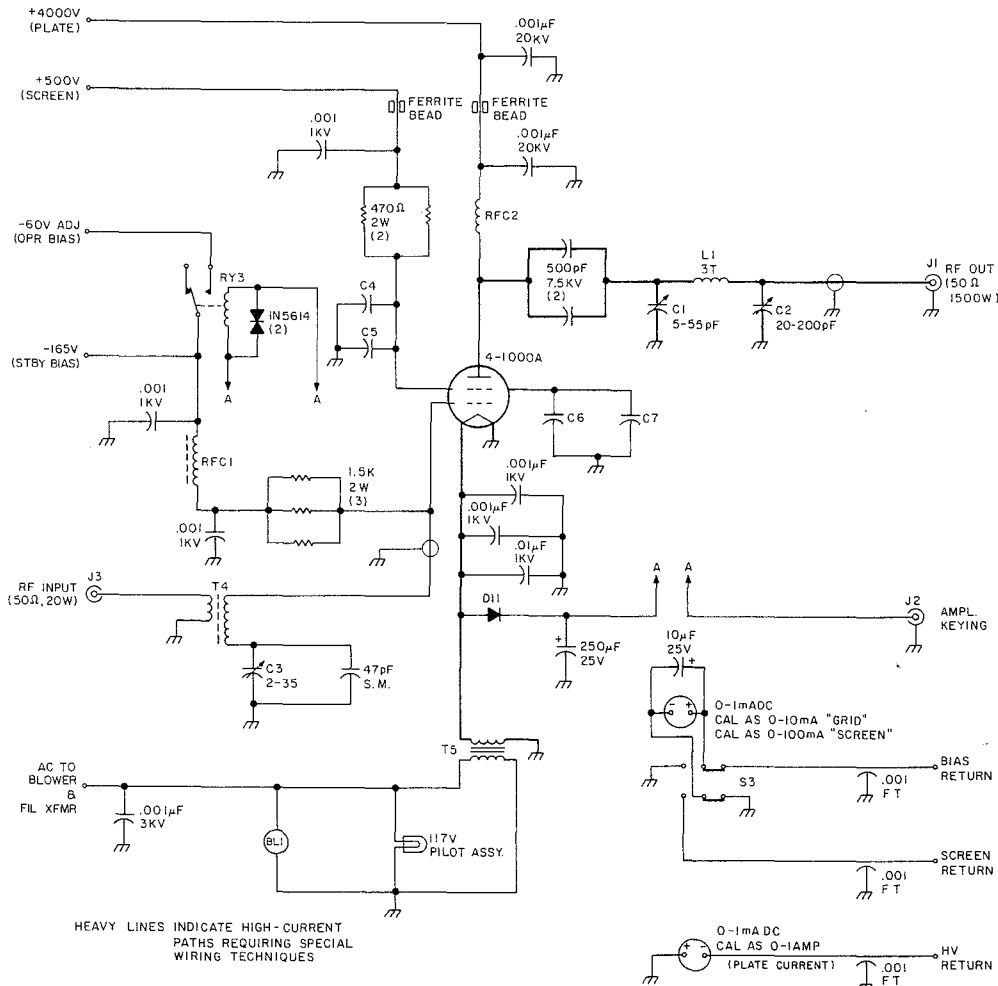

Fig. 2. Rf deck.

lected carefully—I used a #12-4 cable. A smaller cable will have too much IR drop. Remember, this is a 4000-Watt power supply! I run the switched ac and all low-voltage dc lines through a 12-conductor cable to a Cinch-Jones-type power connector which mates with another connector fitted to a similar cable coming from the rf deck. The HV output line is made of 20-kV anode cable fitted with a male Millen-type high-voltage connector at each end.

The completed power supply is not a table-top unit by any means, but it is quite compact for its capability and is attractive enough. The commercial look is imparted by careful construction and good overall workmanship. Wire dress, especially at the 4-kV level, is very important! All plate-supply secondary wiring is 20-kV insulated anode wire.

The rf deck is straightforward. I designed the plate tank circuit for a Q of about 16. A lower Q is not possible with the 4-1000A at 50 MHz because of the tube's high plate capacitance. The tank circuit, a conventional pi network, uses a Jennings vacuum-variable input-tuning capacitor, type GCS-55, a coil made of $\frac{1}{4}$ " copper tubing (3 turns, $1\frac{3}{4}$ " inside diameter, $3\frac{1}{4}$ " long) and a 200-pF air-spaced variable-output capacitor made by E. F. Johnson (type 167-12). The Jennings plate-tuning capacitor is rated at 7500 volts, and this is a recommended unit. It has high Q and very low minimum capacitance, which is required at this frequency. If a Jennings unit cannot be found at reasonable cost, I'd recommend a Millen-type 15011 neutralizing capacitor with $2\frac{1}{4}$ "-diameter plates as a second choice. The object here is high Q and very low minimum C in order to obtain a reasonable overall Q. An ordinary air-spaced variable multi-plate capacitor won't work.

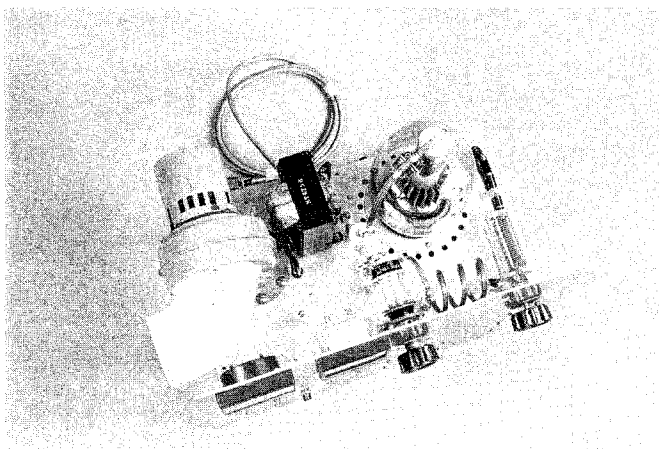

Photo E. Rf deck, top view.

While chassis size for the rf deck is certainly not critical, the deck must be fairly large simply because the 4-1000A is so darned big! My chassis measures $10'' \times 17'' \times 4''$ but could be slightly smaller if the blower were mounted totally outboard. I used an Eimac SK-510 socket, but this shouldn't be critical, as any air-system socket will work fine. These sockets do *not* contain any special screen-bypass capacitor and are of simple construction and low cost. While Eimac and others recommend the use of a glass chimney for the 4-1000A, I didn't use one. Instead, I punched 24 $5/16''$ -diameter holes in a circle pattern around the outside of the socket rim (see Photos E and F) and forced a lot of air through the socket and these holes, thus creating a considerable draft along the tube envelope.

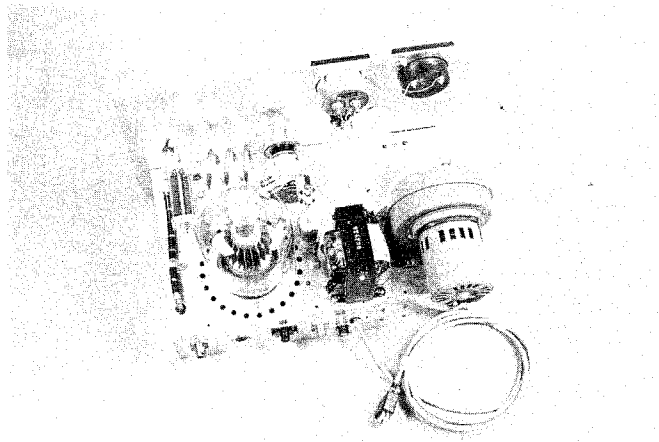

Photo F. Rf deck, top/rear view.

The blower I selected was a Dayton 2C781 (Photos E and F), but any similar or larger blower will work. The object, obviously, is to force a lot of air through the tube base and around the envelope. The more air, the better! I also used a large ($1\text{-}3/8''$ diameter) finned aluminum-plate cap on the tube to help reduce plate-seal temperature.

Since the rf deck chassis must be pressurized, use one with solid, not perforated, walls. Also, be sure to seal any cracks or holes with RTV caulking compound to help maximize pressurization of the under-chassis.

My rf deck has the filament transformer mounted atop the chassis between the blower and the tube. It might be wiser to mount the transformer below the chassis, as the heat radiated by

the 4-1000A adds to the operating temperature of the transformer. I used a filament transformer from Amp Supply Company (Twinsburg, Ohio), type X7.5-21, which cost about \$50. I also obtained several other components, like some 7500-V doorknob capacitors, panel meters, etc., from Amp Supply. Since the 4-1000A filament drain is very high, the wiring must be kept short and the conductor size large. I used #12 insulated wire routed directly to the tube socket.

The input-circuit and plate rf-choke designs were borrowed originally from an *ARRL Handbook* article written around a 4CX1000A amplifier for six meters; however, both items required modification for use with the 4-1000A. The 4-1000A and 4CX1000A, while very different tubes, have similar input capacitance and I reasoned that the *Handbook* circuit would work. It didn't, and I modified both the tuning capacitance and the grid-load resistance to accommodate the 4-1000A characteristics. These revisions are noted in the rf-deck schematic diagram (Fig. 2). Having built other VHF high-powered amplifiers, I already knew something about plate rf chokes and the *Handbook* design, using a 1"-diameter Teflon™ form, looked good. It worked, but flamed out after a few hours of operating time. I rewound the plate rf choke using #20 enamel wire on the same Teflon form and so far this choke has lasted. It is likely that the combination of very high rf voltage across the choke, the considerable dc current through the choke, and its very high ambient temperature (the result of its being located close to the 4-1000A envelope) caused the demise of the original component—which was wound with #24 wire.

The input circuit, shown in both photos and figures,

centers around a single T50-12 ferrite toroid transformer. I obtained both this toroid form and a supply of ferromagnetic beads for decoupling purposes from Amidon Associates (North Hollywood, California), who are very nice people to work with and offered me overnight delivery at reasonable cost.

The plate-blocking capacitor is actually two paralleled 500-pF, 20-kV doorknob units made by Sprague and purchased at a local flea market. The 20-kV rating is unnecessary, but I'd strongly recommend the doorknob design; other types of capacitors just can't handle all the rf current.

The output-circuit configuration and mounting is straightforward as pictured in Photo F. The Jennings vacuum capacitor mounts on three aluminum spacers directly to the front panel, while the tank inductor and loading capacitor mount on ceramic spacers to the chassis. Interconnections between all plate-circuit components are made with copper braid taken from high-quality RG-8/U coaxial cable. The connection from plate tank to the rf-output connector, a type-N receptacle, is made with high-quality RG-8/U routed as far away from the tube envelope as possible to avoid overheating. After all, with this amplifier at maximum output, the rf voltage across the 50-Ohm output cable is about 450 volts peak when the output load swr is 1:1 and can become considerably higher at elevated vswr. The output current is also high in this legal-limit amplifier: About 6.5 Amperes rms will be conducted in the output cable. Needless to say, RG-58/U—even in very short lengths—is *not* recommended!

I used knobs from an old Heathkit SB220 for the plate tune and load controls. The front panel of the rf deck would look a bit boring with just two knobs, so I fancied

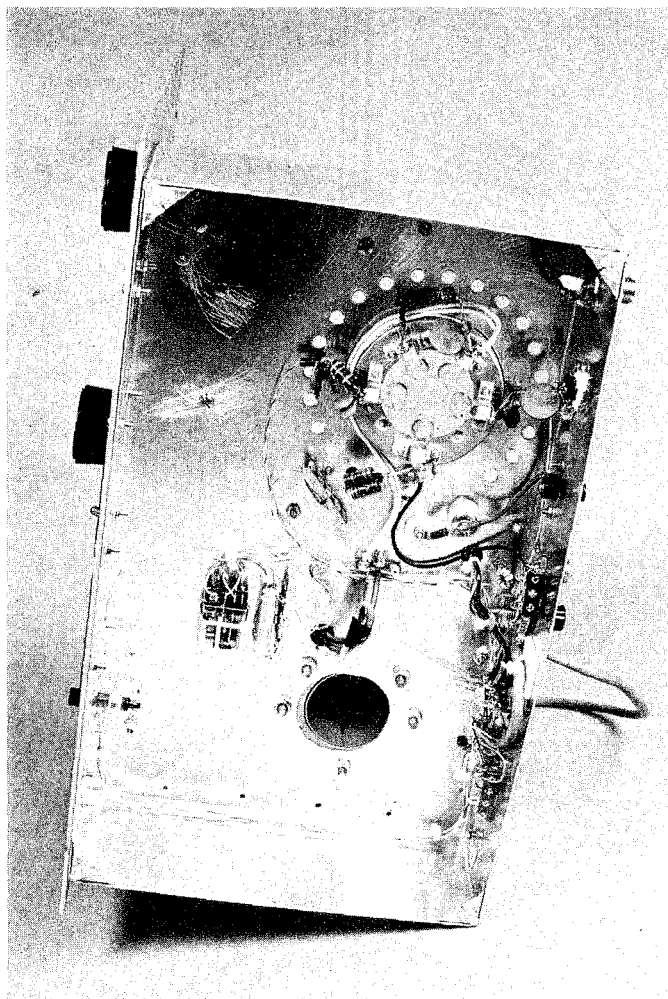

Photo G. Rf deck, bottom view.

it up a bit with a pair of 3/4" panel meters, a meter switch, and a red pilot-lamp assembly to indicate the "on" status of the remote power supply. The right-hand meter reads 0-10 mA dc for grid current and 0-100 mA dc for screen current and is switched with the toggle switch mounted directly below the meter. The left-hand meter monitors plate current and reads 0-1 Ampere dc. My initial testing of the amplifier was performed *sans* rf-deck cabinet (although the bottom cover plate for the chassis must be in place) and I originally intended to look for an old 75A2 cabinet or something to mount the rack panel to and create an enclosure. WA2VUN fabricated the cabinet shown in his welding shop, however, and it is quite functional.

A large hole must be

punched in the cabinet above the 4-1000A to allow free escapement of the cooling air which is forced past the tube. This hole should be at least five inches in diameter and centered directly over the tube. The ventilation hole should be covered with window-screen material or the like to aid in shielding. This amplifier is bound to create a TVI problem, especially in areas with Channel 2 service, whether it is well shielded or not, but proper shielding combined with good power-supply decoupling and an outboard low-pass filter in the antenna feedline should at least help reduce TVI to a manageable level.

When building the rf-deck cover, be sure to allow an adequate air-flow path for the blower intake as well as the exhaust. Mine is ducted from the side of the cabinet

away from the tube to ensure a plentiful supply of cool intake air. While an outboard blower would solve this problem, I intended the deck to be as self-contained as possible without occupying too much depth on the operating bench; I mounted the blower on the rf-deck chassis and ducted the air intake to the cabinet side wall using an elbow made of 3" (inside diameter) PVC tubing.

My first attempt at putting this monster on the air revealed a few weak links, some of which I discussed earlier. One weak point not yet mentioned is the grounding strap which connected the rotor of the plate-loading (output) capacitor to chassis ground. I had built this strap of RG-8/U braid which was soldered to a rotor lug on the 200-pF capacitor and bolted to the chassis. After a few minutes of key-down operation at about one kilowatt output, the solder bonding the braid to the rotor lug melted, disconnecting this ground point and throwing the tank circuit out of resonance. Apparently there are some real hefty circulating tank currents in this amplifier (partially due to its high Q) and solder was not going to do this job!

Adding a parallel ground path, using some .031"-thick aluminum-sheet material, *bolted*, not soldered, between the capacitor rotor connection point and the chassis solved this problem. I bent some sheet aluminum to make a bracket-like assembly and punched it to accommodate the load-capacitor shaft bushing (which is electrically common to the rotor) and then bolted this assembly to connect the capacitor rotor to the rf-deck chassis. This seems to have permanently solved the ground-braid overheating problem.

At this point, I was able to drive the Blockbuster to a good, solid 1500 Watts rf

Parts List

Note: Unless otherwise specified, all resistors are 1/2 Watt, 10%; all capacitors of less than 1 uF are disc ceramic, 1000 Volts. Many values are not critical and may be substituted, as discussed in the text. Other key components are discussed in the text.

BL1	Centrifugal "squirrel-cage" blower	Dayton P/N 2C781 or equiv.	\$20
C1	Plate-tuning capacitor	ITT/Jennings P/N GCS-55 or equiv.	\$15 surplus \$100 new
C2	Plate-load capacitor	E. F. Johnson P/N 167-12 or equiv.	\$5 surplus
C3	Input-tune capacitor	All-Star Products P/N APC-5814 or equiv.	\$5.95 new
C4-C7	Screen-bypass capacitor	Centralab P/N DD30-102 or equiv.	59¢ each new
D1, D2	HV rectifier assembly	Semtech P/N SCHS7500 or equiv.	\$54.74 each new \$10 each surplus
D3-D11	Rectifier, 1000 piv, 1 A	Semtech P/N 1N5620 or equiv.	\$1.51 each
F1, F2	Primary line fuse	Bussmann MDL20 or equiv.	25¢ each
F3	Screen/bias/blower fuse	Bussmann MDL5 or equiv.	25¢ each
F4	Screen center-tap fuse	Bussmann AGC1/8 or equiv.	80¢ each
J1	Rf output receptacle, Type N, Mil type UG-58A/U	Amphenol P/N 82-97 or equiv.	\$3.29 each
J2	Keying receptacle, RCA phono type		20¢ each
J3	Rf input receptacle, UHF type, Mil type SO-239	Amphenol P/N 83-1R or equiv.	89¢ each
L1	Plate tank coil, 3 turns 1/4" copper tubing wound on a 1-3/4" form (which is then removed), 3-1/4" long		Home-brew \$1
RFC1	2.5-uH, 1-Amp choke	J. W. Miller P/N 4606 or equiv.	\$1.95
RFC2	36 turns #20 enameled wire on 1" diameter Teflon™ rod		Home-brew \$5
RY1	DPST or DPDT relay (plate supply primary), 20-Amp, 230-V-ac contact ratings	PRD P/N 7DY0 or equiv.	\$12.95 new
RY2	SPST or SPDT relay	P&B P/N KA5AG or equiv.	\$5.95 new
RY3	SPDT or DPDT relay	P&B P/N KA11DG or equiv.	\$6.95 new
S1, S2	SPST or SPDT toggle switch	Cutler-Hammer P/N 7580K7 or equiv.	\$1.59
S3	DPDT toggle switch	Cutler-Hammer P/N 7591K6 or equiv.	\$1.79
T1	HV (plate) transformer, 230 V ac: 6000 V ac center-tapped, discussed in text.		\$230 new
T2	Multipurpose transformer, 120 V ac: 700 V ac center-tapped, 6.3 V ac and 5 V ac	Fair Radio P/N T52960 or equiv.	\$5.95 (surplus)
T3	Filament transformer (used for bias), 120 V ac: 6.3 V ac @ 2 Amps	Stancor P/N P6466 or equiv.	\$6.95 new
T4	Rf input transformer (toroid), 2 turns #24 enameled wire primary, 10 turns #24 enameled wire secondary, wound on a T-5-12 core. Observe winding polarity.		Home-brew \$1

output into my 50-Ohm Bird oil-cooled dummy load. The exciter power required for legal-limit output is only 25 Watts, yielding an amplifier power gain of 60. This amplifier is very linear, so the 60:1 power gain remains nearly constant over a wide range of driving powers; e.g., 20 Watts drive yields 1200

Watts output, 10 Watts drive yields 600 Watts output, etc. My own six-meter exciter achieves only about 25 Watts peak output, so my station is held down to the legal-limit power level by virtue of drive limitations.

Using WA2VUN's ICOM IC-551D, which can develop about 80 Watts peak output

power, I was able to drive the Blockbuster to considerably beyond legal output power. Even at 1.8 kW CCS output, the 4-1000A draws no grid current at all and the plate color is a bright but entirely reasonable shade of red. I don't recommend running this power level for two very good reasons: (1) It ex-

ceeds the plate dissipation rating of the 4-1000A—and this will undoubtedly shorten operating life—and (2) it is illegal.

This is the point where authors of amplifier articles start weaving tales of "strongest signal on the band" reports received. Not to change fifty years of convention, I'll report that my local contest club, SCORE (the Society of Contest Operators and Radio Experimenters), using the callsign K2XR from Western New York, used the Blockbuster on six meters during our operation in the ARRL June VHF QSO Party (1984) and we never had to call anybody twice! We did indeed receive many "strongest signal on the band" reports and did not receive a single report of splattering, distortion, or any similarly discouraging words. We used an IC-551D exciter and a pair of 7-element KLM yagi antennas at sixty feet, thus developing about 54 kilowatts effective radiated power (taking feedline loss into consideration). With this setup, we worked numerous meteor-scatter contacts with a very high level of success. Eureka! My goal, stated in the very first paragraph of this article, was achieved.

I might mention that once you've built the power supply for the Blockbuster, it becomes the foundation on which to build various other high-powered rf decks. My next project probably will be a legal-limit 160-meter monoband amp using another 4-1000A. The supply described in this article is super. Reasonably small and affordable, it delivers all necessary operating voltages for a wide variety of high-powered triodes or tetrodes.

Thanks to KT2B for the excellent photographic work and, as mentioned earlier, to WA2VUN and W2HWG for sheet-metal fabrication.

CU on six! ■